

# Instructions Maxim 3000® Turbo Stainless Bowl/Fill Port

**INTRODUCTION:** Satellite portable restrooms and accessories must be assembled according to approved assembly procedures. Avoid variations in assembly procedures, which could adversely affect product life and warranty.

## HARDWARE:

#19629 KIT, MX3 TURBO F/FLSH SS/BOWL

17	11368	4	WASHER, 5/16 FLAT STNLS
16	11315	4	WASHER, 3/16 RIVET STNLS
15	12382	2	WASHER, 1/4 FLAT STNLS
14	16884	2	T-NUT, 1/4-20 X 3/4 PLTD
13	19585	1	SPACER, STNLS BOWL
12	20690	4	RIVET, #614 ALUM
11	17436	4	RIVET, AVDEL SILVER
10	17224	1	PLUG, 1-5/8 ROUND HOLE
9	16858	1	PLATE, FILL/PUMP-OUT
8	19628	1	INSTRUCTION, MX3 TURBO SS BOWL
7	17318	1	ICON, UPGRADE DECAL
6	15968	1	HOSE, 1 X 8 GREEN
5	17169	1	HINGE, FLUSH BOWL
4	21150	1	DECAL, FOOT FLUSHING
3	10281	1	CLAMP, WORMDRIVE #20
2	18973	1	BOWL ASSY, FLUSH STNLS
1	19381	2	BOLT, 1/4-20 X 1/2 PN HD STNLS
ITEM #	PART #	QTY	DESCRIPTION

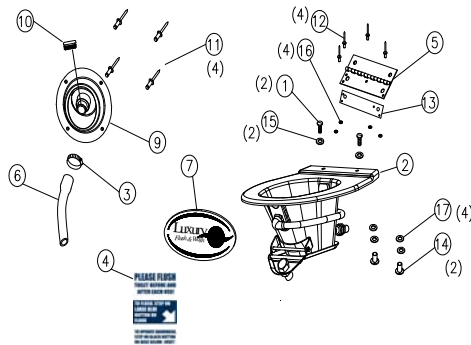

## Tools:

- DRILL ELEC/CORDLESS
- STANDARD SCREWDRIVER
- PHILLIPS SCREWDRIVER BIT
- 5/16"[8MM] NUT DRIVER BIT
- RIVET GUN
- HOLE SAW 2.00"[50mm]
- RECIPROCATING SAW
- #10 DRILL BIT

1. Insert end of inlet hose into 1-1/8 [29mm] hole in top of base. **SEE FIG #1**
2. Drill 2" [50mm] hole on dimple, located on the right side of the tank. Insert the outlet hose into hole. **SEE FIG #2**
3. Using the plastic screws supplied with toilet seat and the hinge as a fixture. Insert screws through holes in hinge and in tank holes for the toilet seat. Drill (4) #10 [5mm] holes through hinge, spacer and tank. Fasten with rivets and washers. Washers on the inside of tank. **SEE FIG #3**

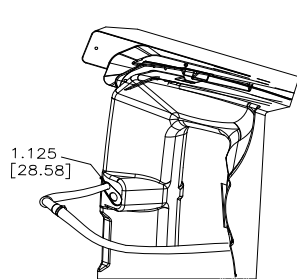

FIG #1

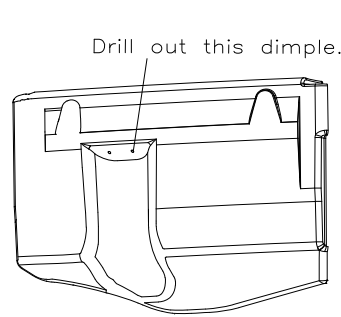

FIG #2

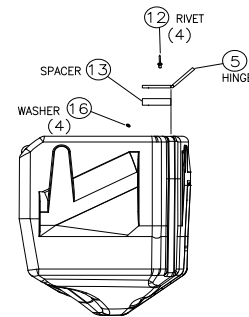

FIG #3

4. Measure from dimple on front rim of tank over to the right 3.50" and repeat on the left side. Measure from outside edge on front rim of tank approx. 1.125" should see a visible line on rim of tank, cut on that line starting at dimple. Place bowl in tank opening and if needed cut out area to create clearance for bowl flapper. **SEE FIG #4**
5. Loosen hose clamp and cut elbow off hose as close to elbow end as possible. Attach hose to bowl. **SEE FIG #5**
6. With hinge open, place T-nuts in the (2) large holes in hinge. Place washers on bolts. Insert bolts and washers through seat lid hinge and just start in T-nut. Center seat lid on bowl and tighten bolts. **SEE FIG #6**

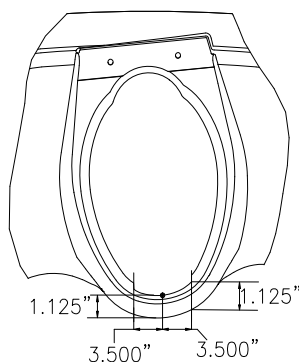

FIG #4

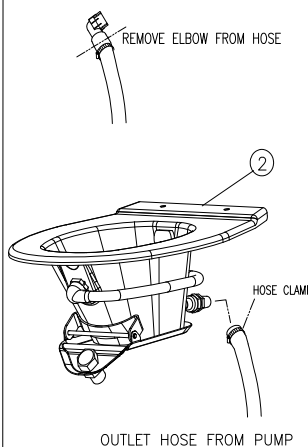

FIG #5

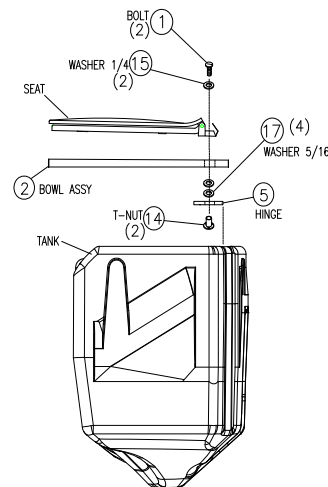

FIG #6

7. Fasten hose to plate fill/pump out with hose clamp. SEE FIG #7
8. Drill out hole in rear panel. If using a hole saw, use a 5-1/2" hole saw and use dimple in panel for starting point. If using a jig saw, cut out outside edge of the recess. SEE FIG #8

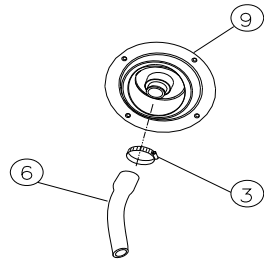

FIG #7

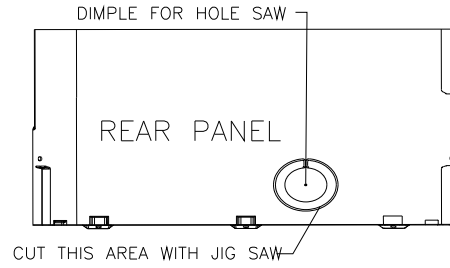

FIG #8

9. Insert the large hose into the 1-1/2" [38mm] hole in base. Note the curvature of the hose goes downward and fits into the hole in the base hole without kinking. SEE FIG #9
10. Fasten plate to panel. Using the plate as a fixture, drill out a one of the holes with a #10 [5mm] drill bit. BEING CAREFUL TO JUST DRILL THROUGH FIRST LAYER. Fasten plate to panel with rivet and repeat step to (3) remaining holes in plate. SEE FIG #10
11. Push plug in plate hole. SEE FIG #10

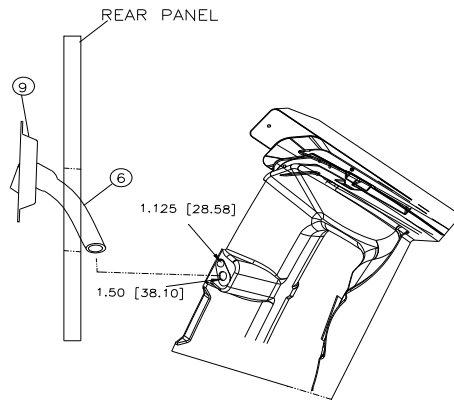

FIG #9

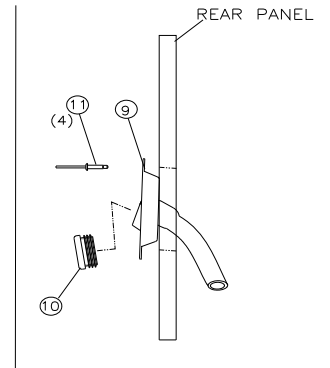
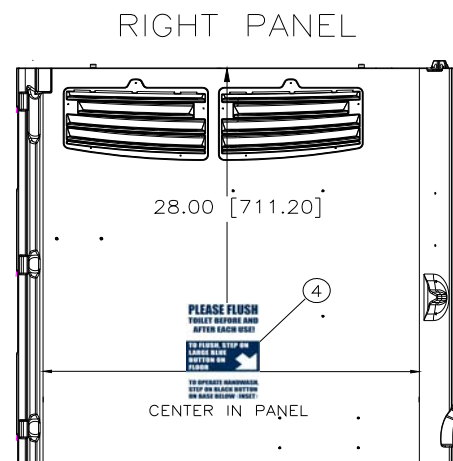
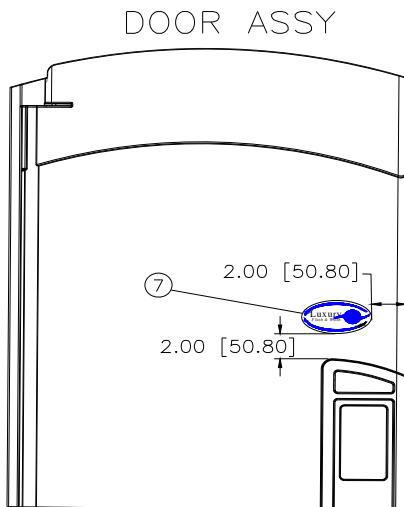

FIG #10

12. Apply Icon and decal to door and panel.



2530 Xenium Lane North, Minneapolis, MN 55441  
 Telephone: 763-553-1900 Fax: 763-553-1905  
 800-328-3332 / www.satelliteindustries.com