

INSTRUCTIONS

WESTERN HAND FLUSH KIT ASSEMBLY

INTRODUCTION

Portable restrooms and accessory kits must be assembled according to approved assembly procedures. Avoid variations in assembly procedures could adversely affect product life and warranty.

HARDWARE

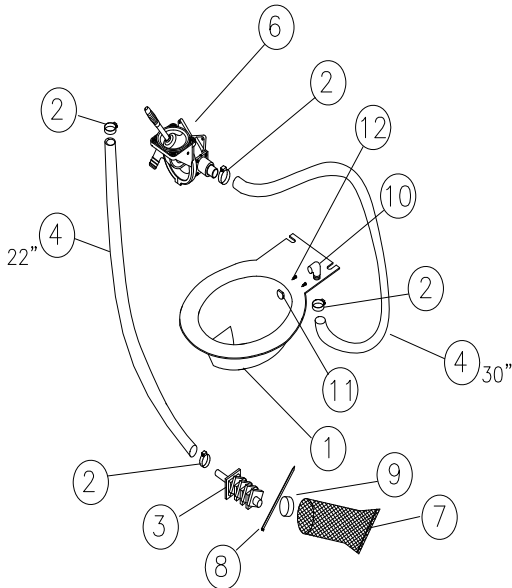

△ #18473 BOWL ASSY, FLUSH-II

| | | | |
|----|-------|---|-------------------------------|
| 12 | 15537 | 2 | SCREW, #4 X 3/8 FH STNLS |
| 11 | 14403 | 1 | NOZZLE, SINGLE SLOT FLUSH |
| 10 | 10451 | 1 | ELBOW, 90 3/4 FPT X 1 INS PVC |
| | | 1 | BOWL, FLUSH |

#15643 KIT, H/FLSH WEST/BOWL RECIR

| | | | |
|---|-------|----|--------------------------------|
| 9 | 17331 | 1 | WEIGHT, TURBO RECIRC FILTER |
| 8 | 11261 | 1 | TIE, WIRE 6in |
| 7 | 16949 | 1 | SCREEN, TURBO RECIRC FILTER |
| 6 | 19173 | 1 | PUMP, BILGE W/ELBOW |
| | 15644 | 1 | INSTRUCTION, WEST H/FLSH RECIR |
| 4 | 14384 | 52 | HOSE, #44 FLEX |
| 3 | 15143 | 1 | FILTER, RECIRCULATING FLUSH |
| 2 | 12588 | 4 | CLAMP, WORMDRIVE #12 |
| 1 | 18473 | 1 | BOWL ASSY, FLUSH-II |

TOOLS

*Drill Elec/Cordless *5/16 Drill Bit *3-1/2 Hole saw *Flat blade Screwdriver *Utility Knife *Pencil

1. Drill Pump Mounting Holes: Find the tank that you will be mounting the Hand Flush kit too. Measure to center as shown and mark with pencil. With 3-1/2 hole saw, drill through tank wall. Center top plate (this will be with #19173 pump) over 3-1/2 hole. Mark the (4) holes with pencil. Remove plate and drill (4) with 5/16 drill bit. On some tanks you may have to cut a slot in the opening for the hose and elbow clearance. Do that at this time as shown.

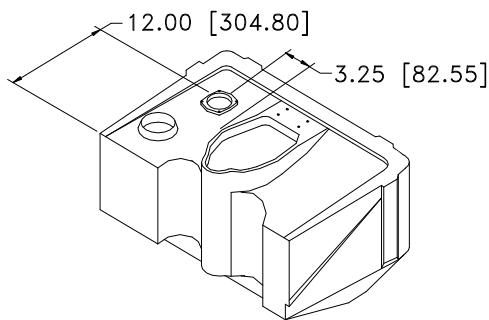

#14765 MX2 TANK

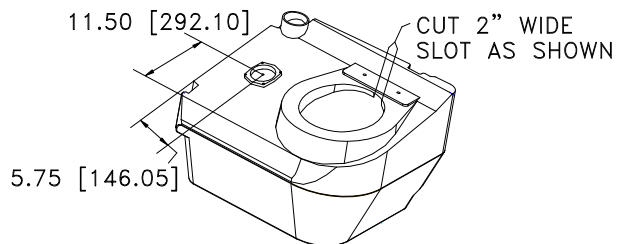

#14508 LIBERTY SMALL TANK

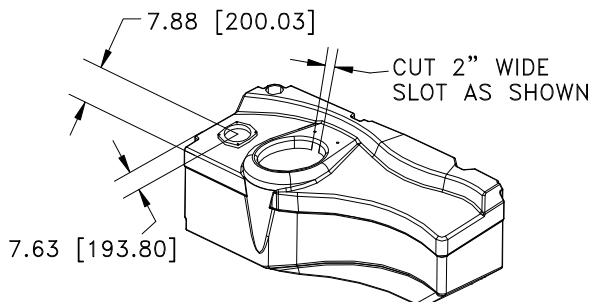

#16538 FREEDOM2 LARGE TANK

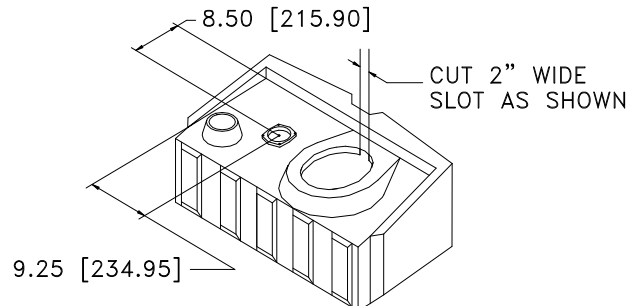

#10553 TUFWAY TANK

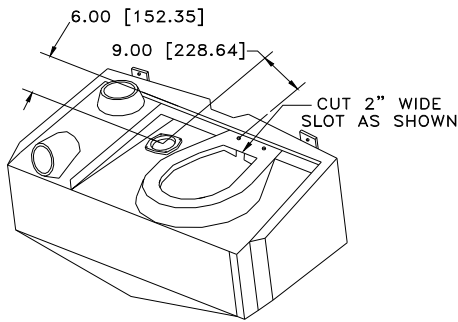

#18698 HIGH TECH TANK

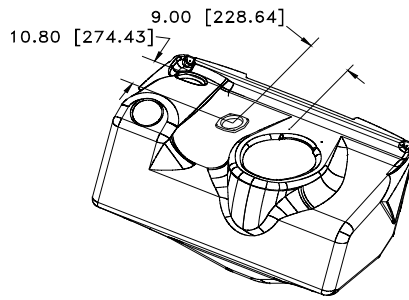

#18934 TAURUS TANK

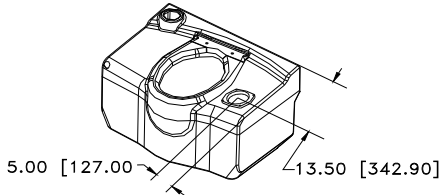

#20814 HIGH RISE TANK

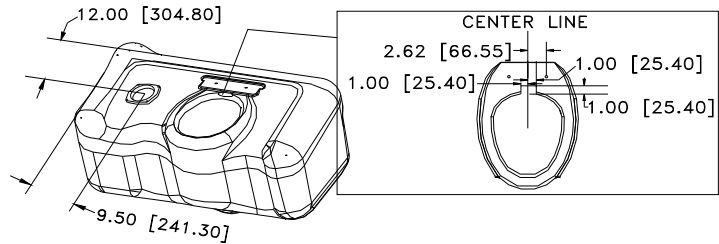

#40017 GLOBAL TANK

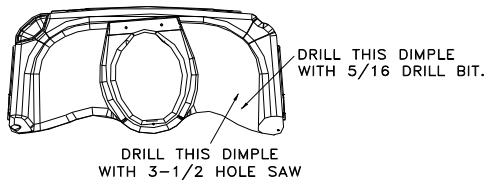

#16690 MX3 TANK

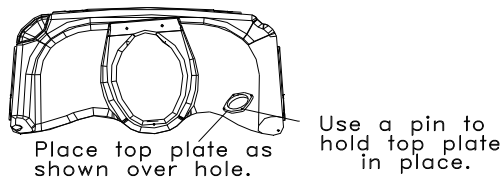

2. Fasten Handle, Boot, Hose and Pump as Shown.

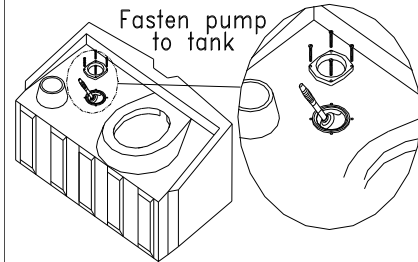
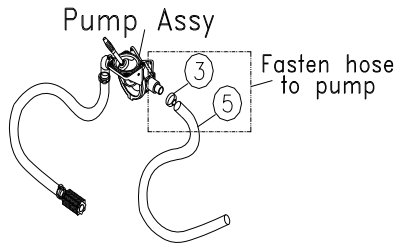
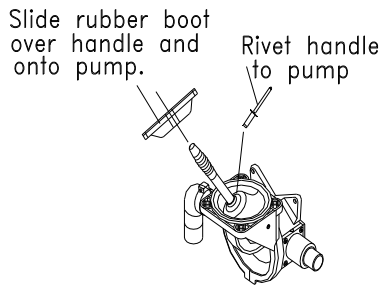

3. Fasten Bowl to tank and Hose to Bowl as Shown.

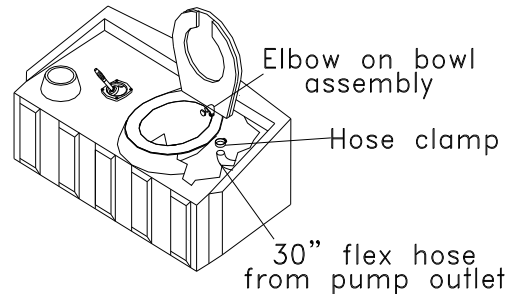
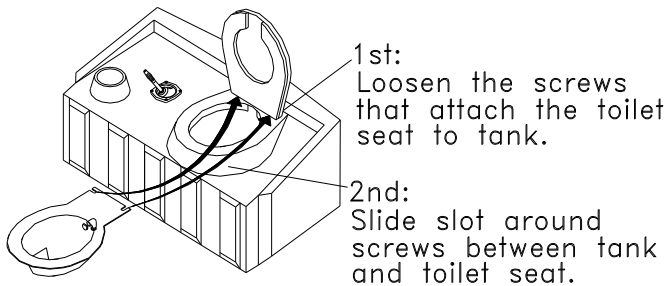

2530 Xenium Lane North, Minneapolis, MN 55441
 Telephone: 763-553-1900 / Fax: 763-553-1905
 800-328-3332/ www.satelliteindustries.com